

REVISIONS				
P.	LTN	DESCRIPTION	DATE	APVD
A10		REVISED PER ECO-15-003872	25MAR2015	DD DS
A11		REVISED PER ECO-16-003526	09MAR2016	JM DS

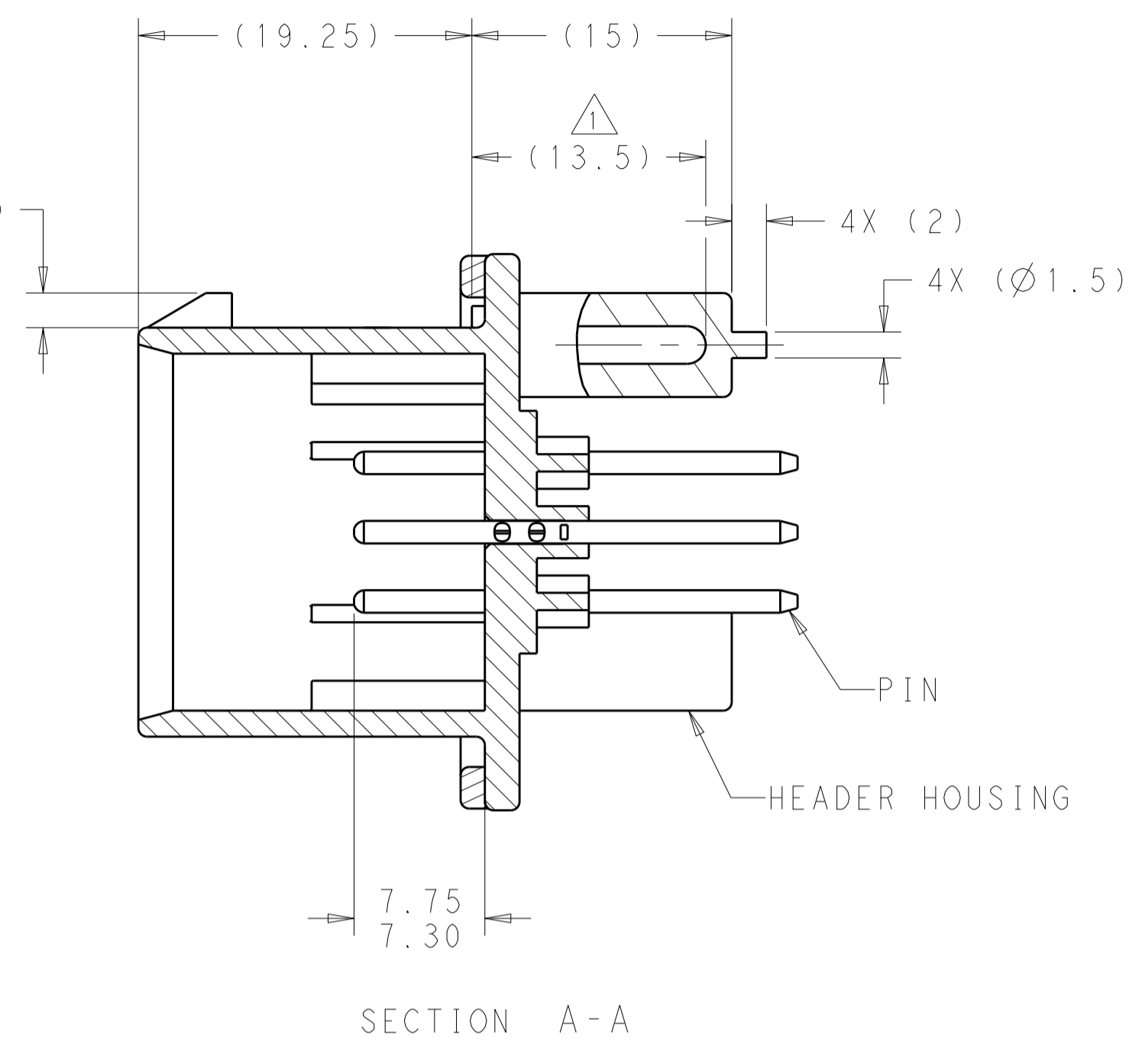

- 1 ACCEPTS #3 SELF TAPPING THREAD FORMING SCREWS OR METRIC EQUIVALENT. DRIVE TO 0.6-0.8 N-m
- 2 DATE CODE IN THIS LOCATION USING 5 DIGIT CODE FIRST 2 DIGITS = YEAR, SECOND 2 DIGITS = WEEK LAST DIGIT = DAY.
- 3 MATERIALS: HEADER HOUSING - GLASS FILLED PBT  
PINS - TIN OR GOLD PLATED BRASS  
GASKET - SILICONE
- 4 HOUSING COLORS ARE MECHANICALLY KEYPED TO MATE ONLY WITH IDENTICALLY COLORED PLUG ASSEMBLIES.
- 5. HEADER MATES TO PLUG ASSEMBLY 776164 WHICH USES REELED TERMINAL 770520 OR LOOSE PIECE TERMINAL 770854

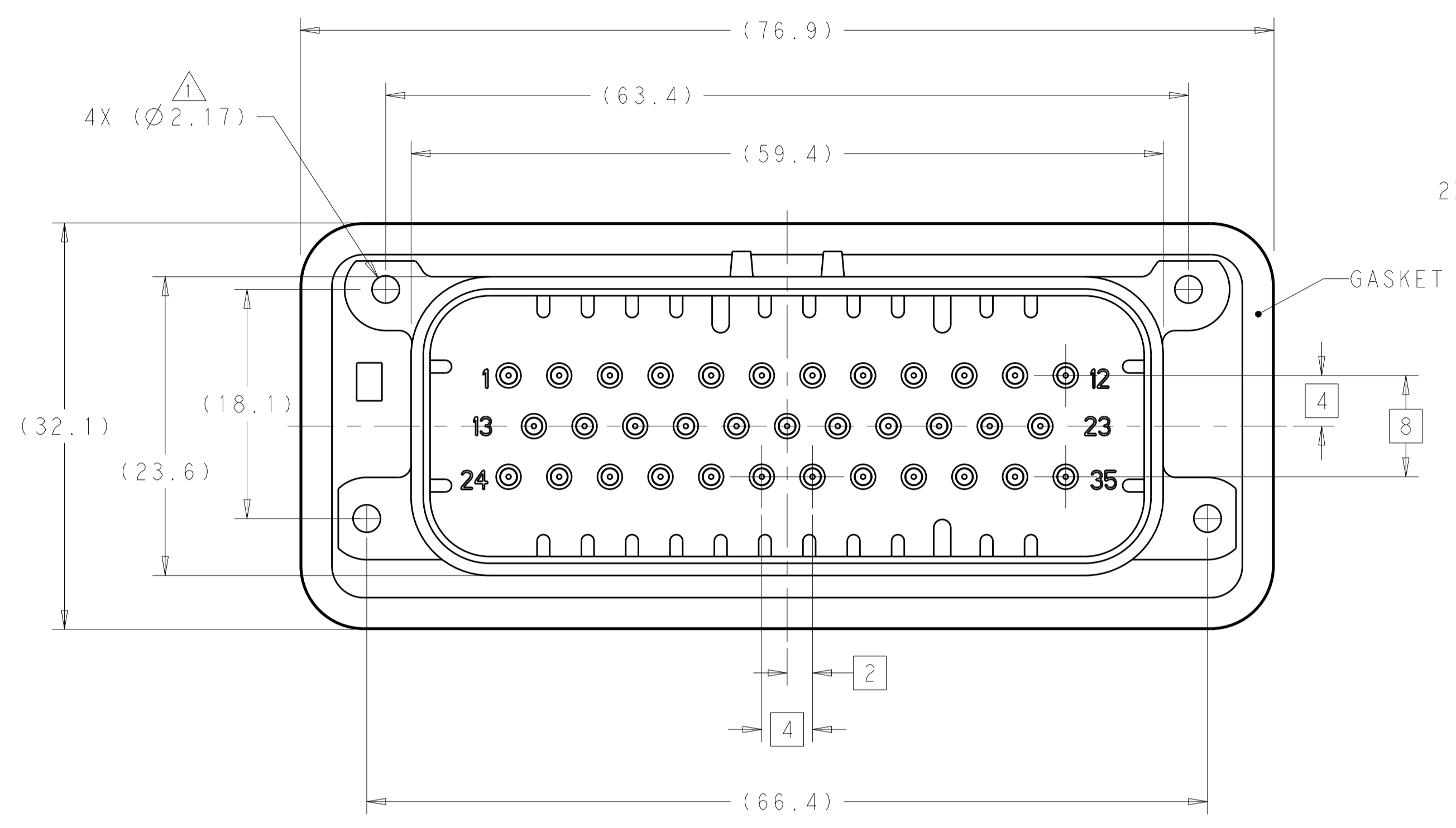
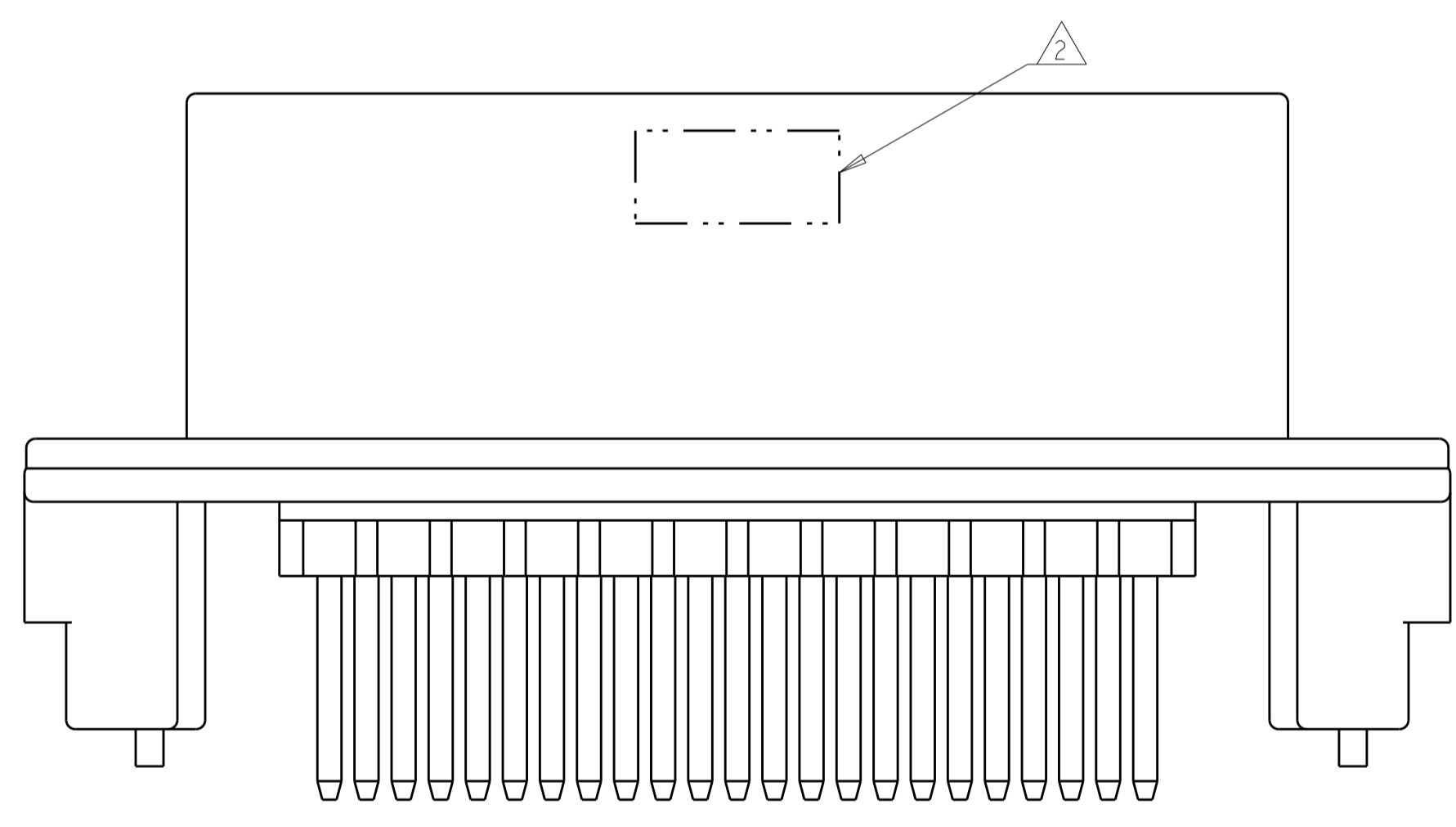

776231-1 & 1-776231-1 SHOWN

HEADER COLOR	PLATING	PART NUMBER
ORANGE	DURAGOLD	1-776231-6
BLUE	DURAGOLD	1-776231-5
GRAY	DURAGOLD	1-776231-4
NATURAL	DURAGOLD	1-776231-2
BLACK	DURAGOLD	1-776231-1
BLUE	TIN	776231-5
GRAY	TIN	776231-4
NATURAL	TIN	776231-2
BLACK	TIN	776231-1

THIS DRAWING IS A CONTROLLED DOCUMENT.		DWN: D. STRAUSSER 05MAR2010 CHK: D. STRAUSSER 22MAR2010 APVD: D. STRAUSSER 27APR2010	<b>TE</b> TE Connectivity	
DIMENSIONS: mm 	TOLERANCES UNLESS OTHERWISE SPECIFIED: 0 PLC ±. 1 PLC ±0.2 2 PLC ±0.13 3 PLC ±. 4 PLC ±. ANGLES ±°	PRODUCT SPEC: 108-1329 APPLICATION SPEC: 114-16016 WEIGHT:	NAME: ASSEMBLY, HEADER, 35 POSITION, VERTICAL, AMPSEAL WITH FLANGE SEAL SIZE: A100779C=776231 SCALE: 3:1 SHEET 1 OF 2 REV: A11	
MATERIAL:		CUSTOMER DRAWING		

REVISIONS				
P.	LTH	DESCRIPTION	DATE	APVD
-	-	SEE SHEET 1	-	-

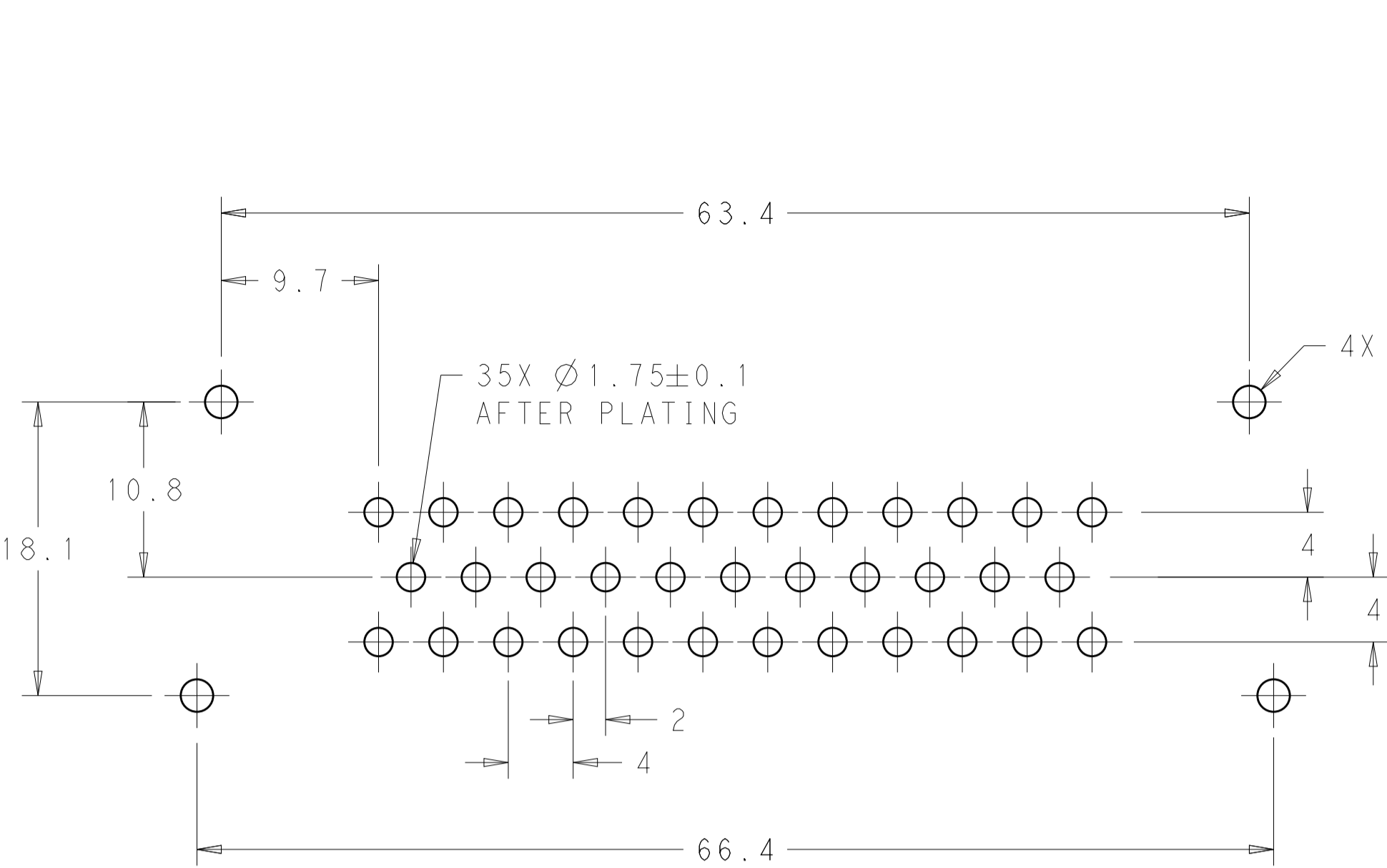

RECOMMENDED P.C. BOARD LAYOUT FOR 1.57 THICK P.C. BOARD

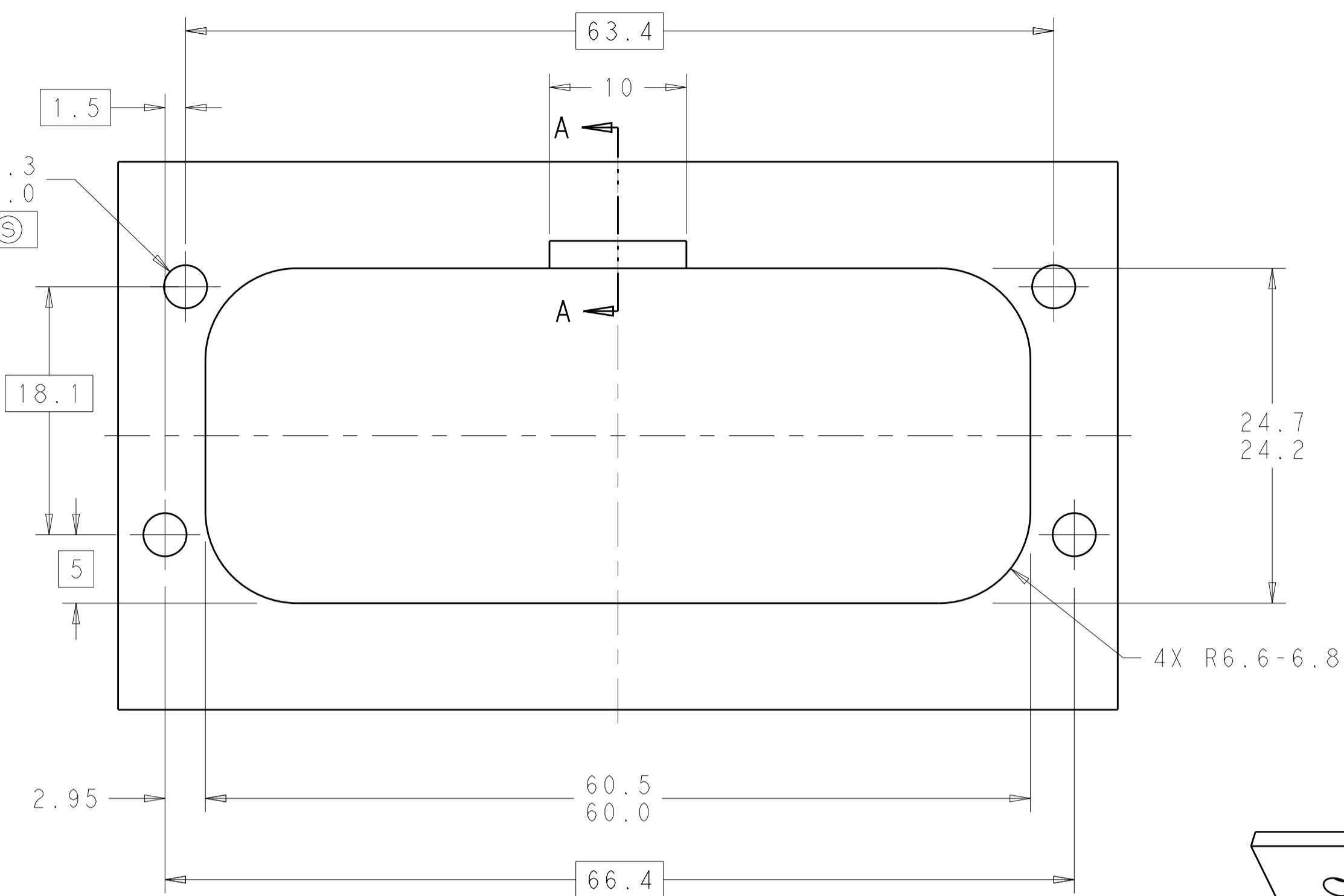

RECOMMENDED MOUNTING HOLE LAYOUT FOR 5.0 MAX THICK PANEL

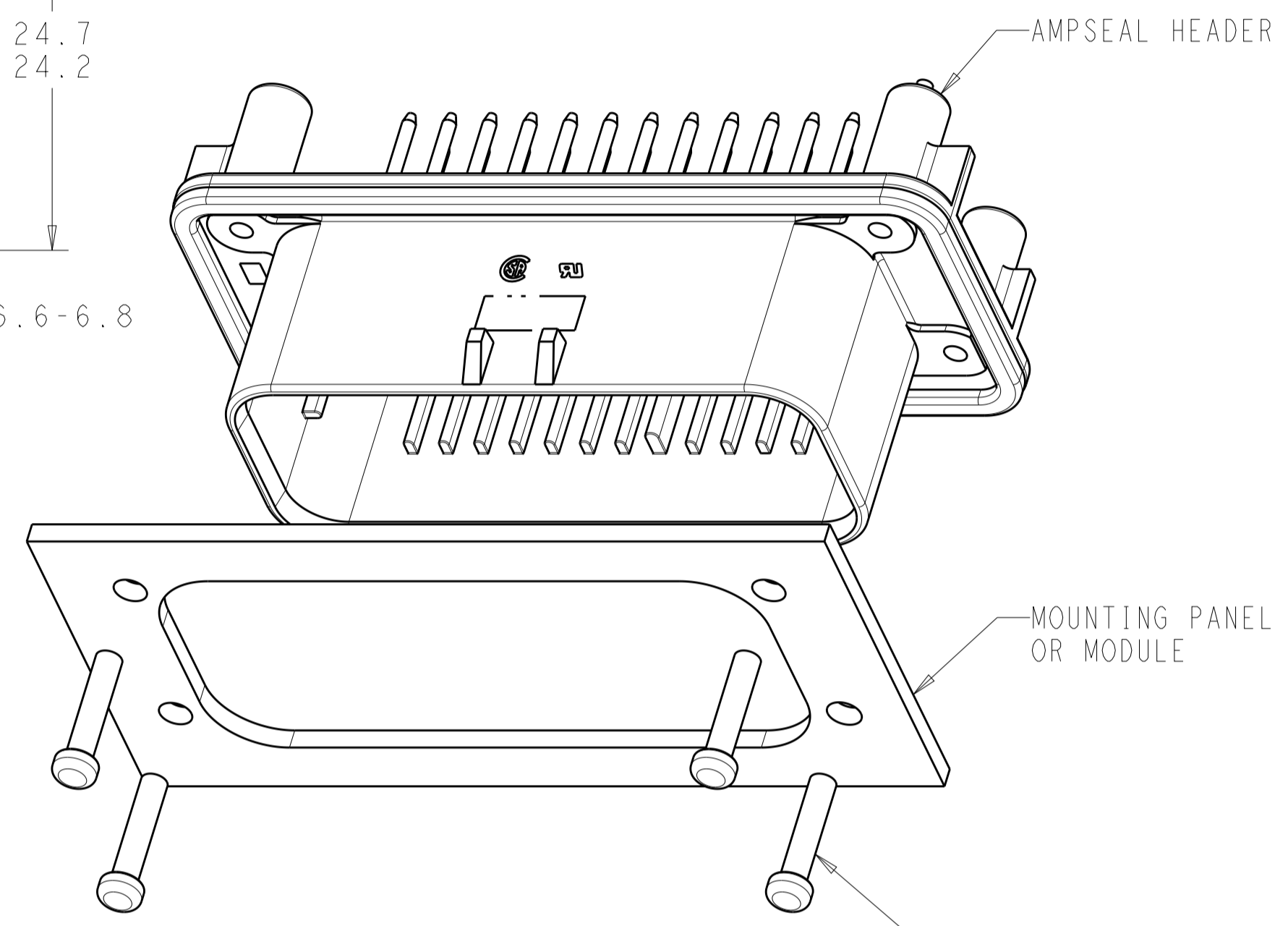

SCALE 2:1

MOUNTING SCREW (4)  
 TORQUE TO 0.6N-m TO 0.8N-m

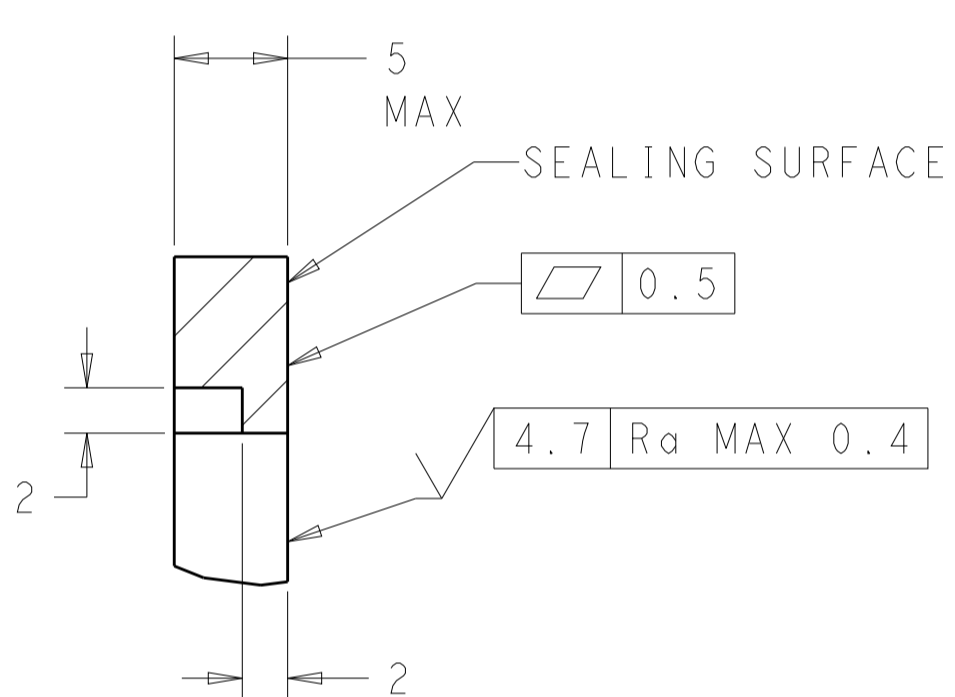

SECTION A-A  
 OPTIONAL CONSTRUCTION IF PANEL THICKNESS IS GREATER THAN 2.0

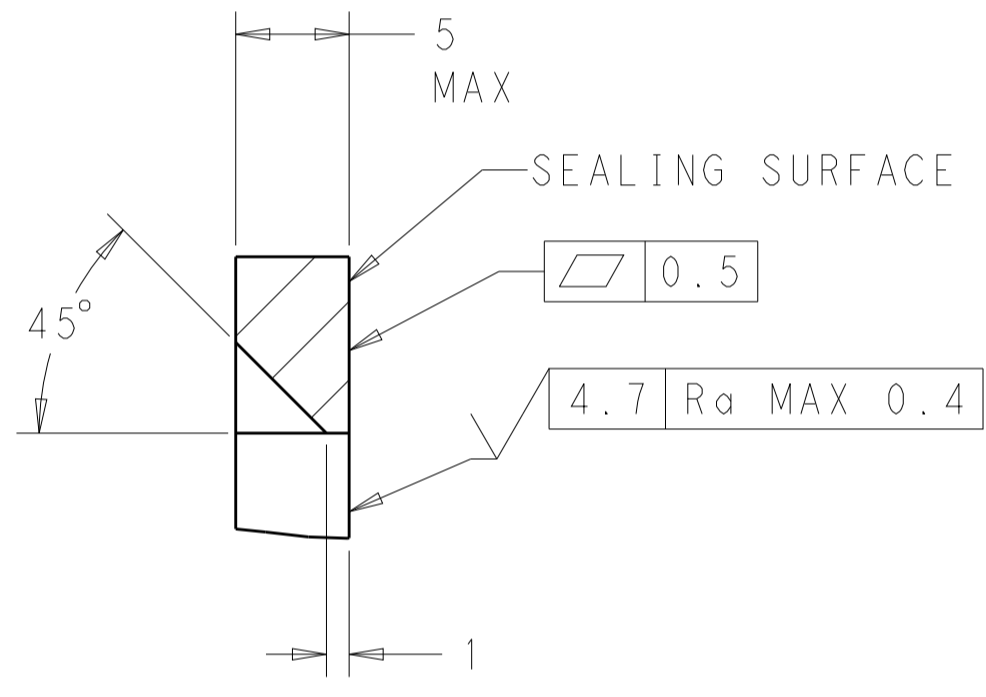

SECTION A-A  
 OPTIONAL CONSTRUCTION IF PANEL THICKNESS IS GREATER THAN 2.0

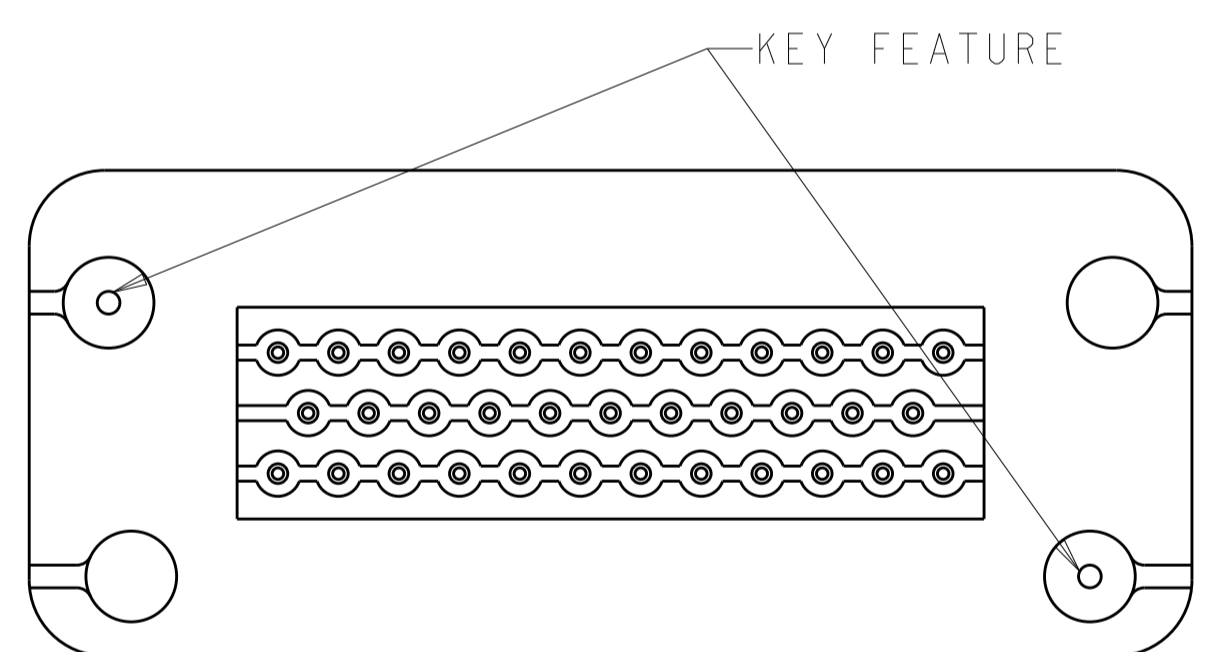

KEYING FOR 776231-1, 1-776231-1, 776231-4, 1-776231-4 AND 1-776231-6  
 SCALE 2:1

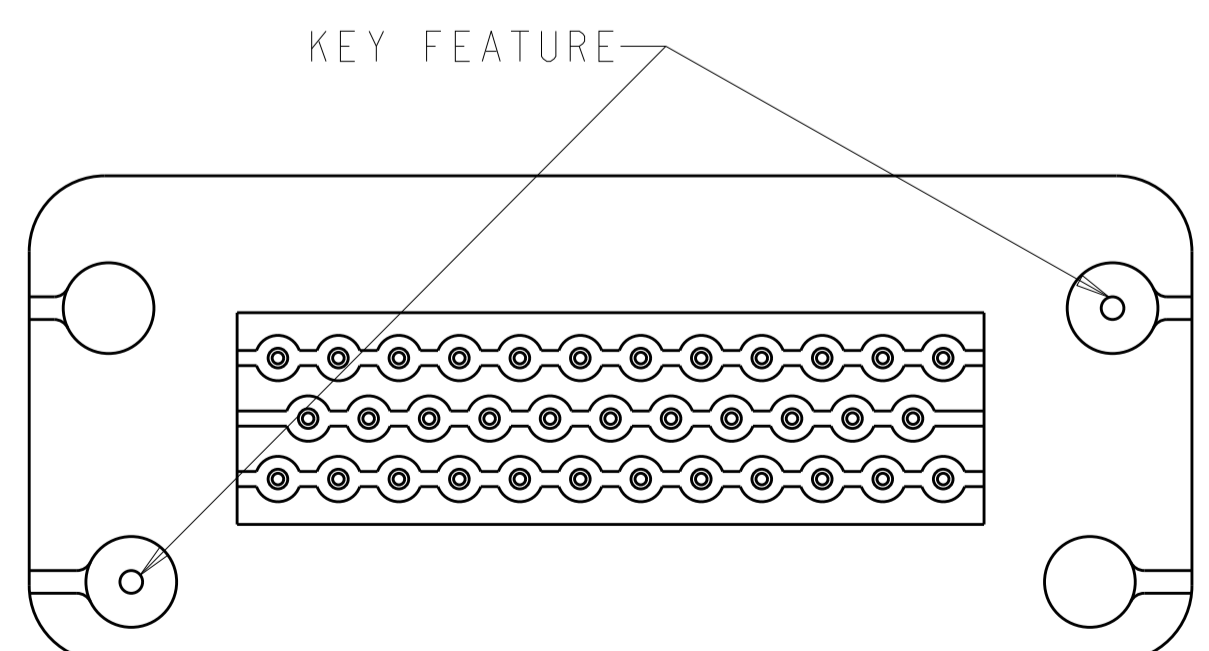

KEYING FOR 776231-2, 1-776231-2, 776231-5 AND 1-776231-5  
 SCALE 2:1

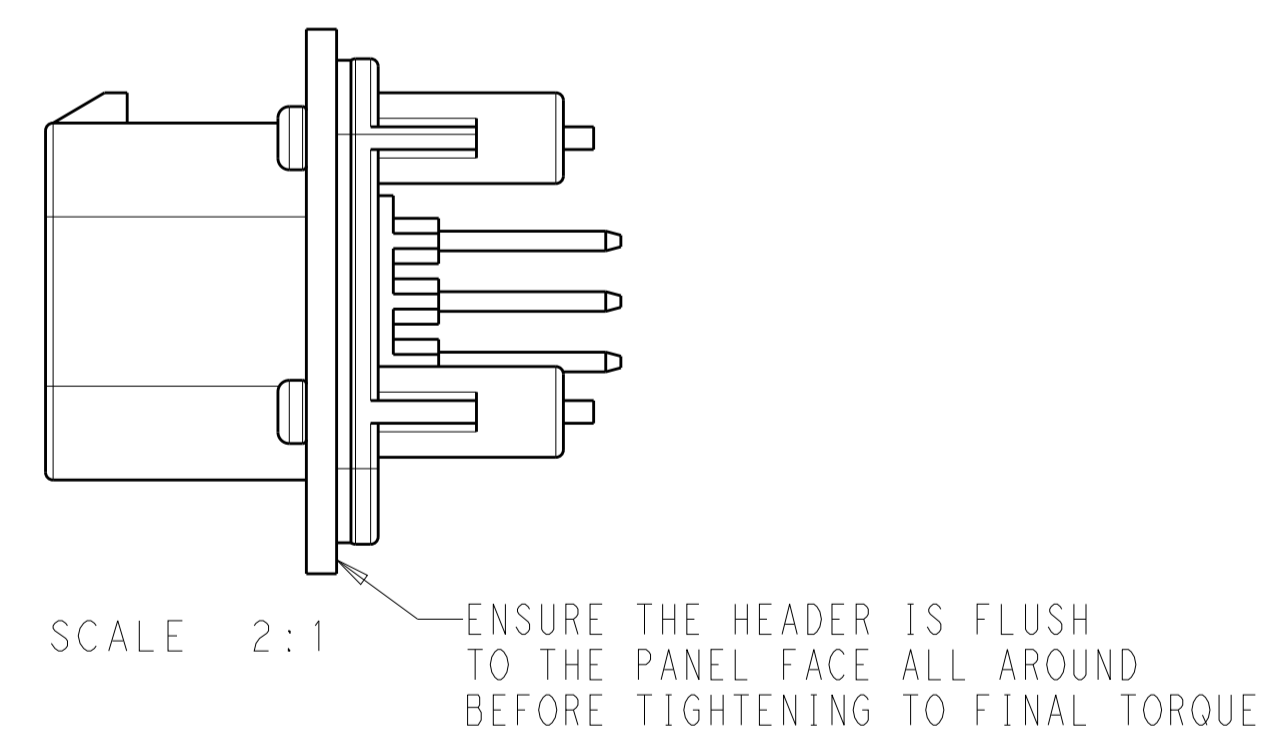

SCALE 2:1

ENSURE THE HEADER IS FLUSH TO THE PANEL FACE ALL AROUND BEFORE TIGHTENING TO FINAL TORQUE

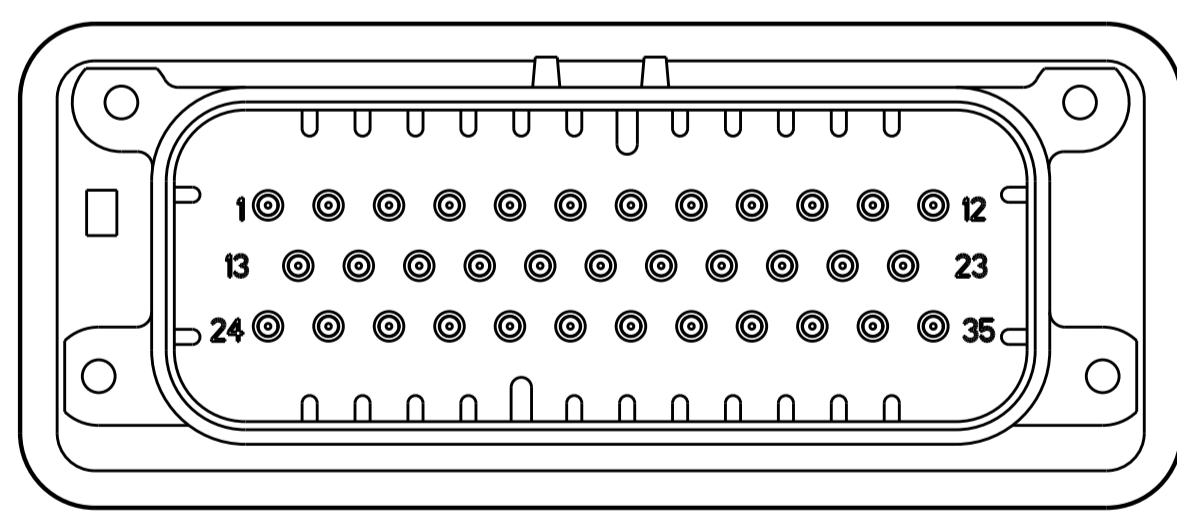

776231-2 & 1-776231-2  
 KEY LOCATION  
 SCALE 2:1

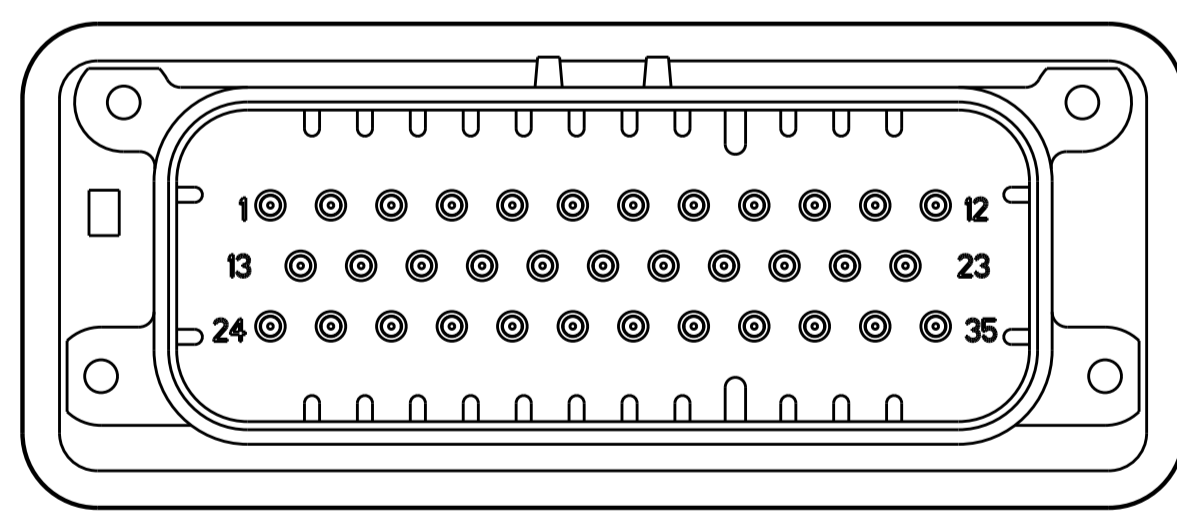

776231-4 & 1-776231-4  
 KEY LOCATION  
 SCALE 2:1

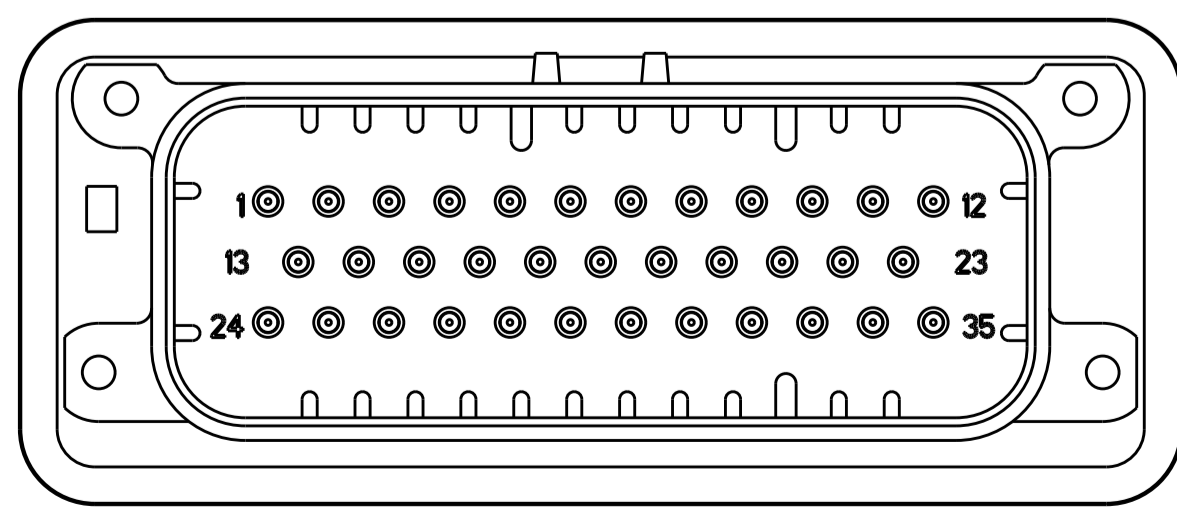

776231-5 & 1-776231-5  
 KEY LOCATION  
 SCALE 2:1

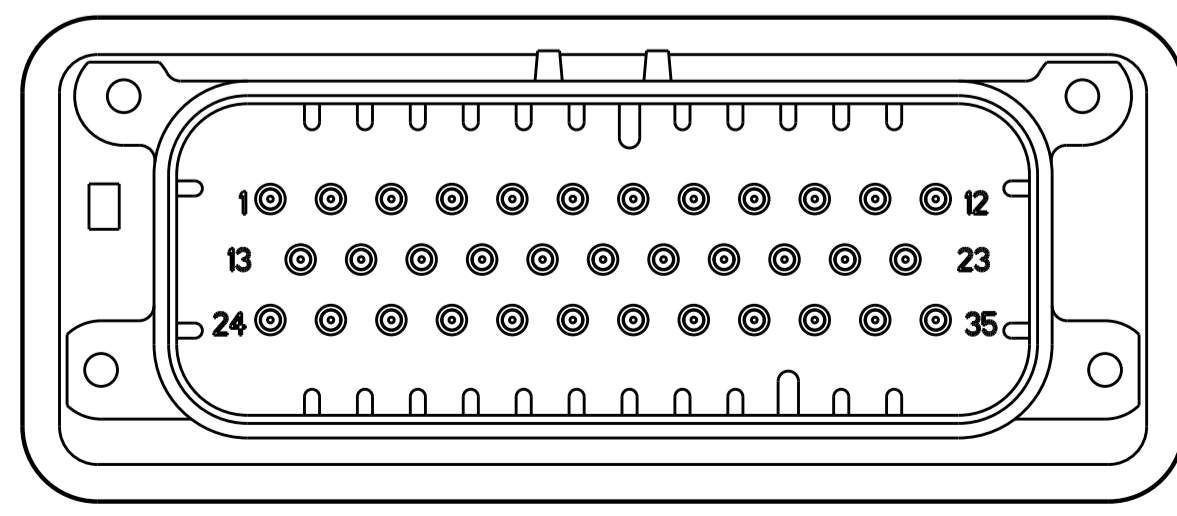

1-776231-6  
 KEY LOCATION  
 SCALE 2:1

THIS DRAWING IS A CONTROLLED DOCUMENT.		DWN: D. STRAUSSER 05MAR2010 CHK: D. STRAUSSER 22MAR2010 APVD: D. STRAUSSER 27APR2010 PRODUCT SPEC: 108-1329 APPLICATION SPEC: 114-16016 WEIGHT: - CUSTOMER DRAWING: -	NAME: ASSEMBLY, HEADER, 35 POSITION, VERTICAL, AMPSEAL WITH FLANGE SEAL SIZE: A1 CAGE CODE: 00779 DRAWING NO: 776231 SCALE: 2:1 SHEET: 2 OF 2 REV: A11
DIMENSIONS: mm TOLERANCES UNLESS OTHERWISE SPECIFIED: 0 PLC ±0.2 1 PLC ±0.2 2 PLC ±0.13 3 PLC ±0.13 4 PLC ±0.13 ANGLES ±45° FINISH: -	MATERIAL: - FINISH: -	RESTRICTED TO: -	TE Connectivity